

Distributed Microphone Array Signal Processing for Hearing Aids

Prof. Dr. Simon Doclo

Signal Processing Group, University of Oldenburg

simon.doclo@uni-oldenburg.de

<http://www.sigproc.uni-oldenburg.de>

Outline

- Hearing instruments: bilateral vs. **binaural processing**
 - Information exchange using wireless link
- **Binaural noise reduction techniques**
 - Objective: noise reduction and binaural cue preservation
 - Binaural beamforming, CASA, Multi-channel Wiener filter
 - Experimental results
- **Bandwidth reduction**: transmit only one contralateral signal
 - iterative **distributed** MWF → converges to binaural MWF
- Effect of **capacity of wireless link** on performance
- Extension to **acoustic sensor networks**

Hearing impairment

- Hearing aids
 - Problems
 - Bilateral - binaural
- Binaural processing
- Bandwidth reduction
- Acoustic sensor networks
- Conclusion

- Hearing impairment effects about **15%** of population
- **Sensorineural hearing loss**: damage to the hair cells in the cochlea

- Increased hearing threshold
- Reduced dynamic range
- Reduced frequency selectivity

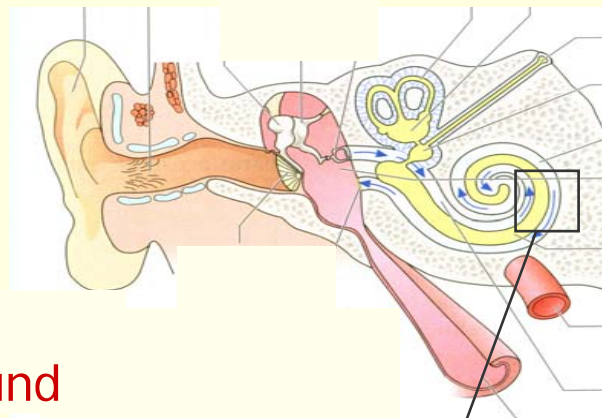

Understanding speech in background noise = very difficult!

- **Severity of hearing loss**
 - o Mild to severe → hearing aid
 - o Profound hearing loss / deafness → cochlear implant

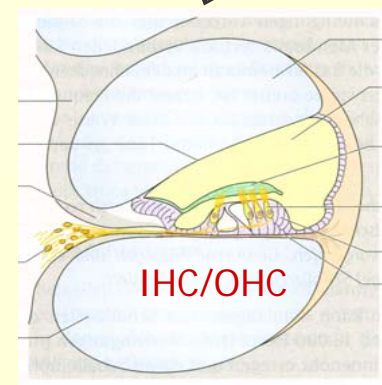

Hearing instruments

- Hearing aids
 - Problems
 - Bilateral - binaural
- Binaural processing
- Bandwidth reduction
- Acoustic sensor networks
- Conclusion

- Possibilities with analog hearing aids = limited!
- **Developments** in HW and micro-electronics:
 - Digital signal processor
 - Multiple microphones (2-3)
 - Binaural wireless link between hearing aids
- Digital hearing instruments and cochlear implants allow for **advanced acoustical signal (pre-)processing**
- Important algorithmic **constraints**:
 - Input-output latency ($< 10...15$ ms)
 - Power constraints from small battery



Hearing instruments

- Hearing aids
 - Problems
 - Bilateral - binaural
- Binaural processing
- Bandwidth reduction
- Acoustic sensor networks
- Conclusion

- Basic processing: **acoustic amplification and dynamic range compression** (frequency-selective)
- Due to acoustic coupling between receiver and microphone (large amplification): **acoustic feedback control**
- Increase speech intelligibility in background noise: **single- or multi-microphone noise reduction and dereverberation**

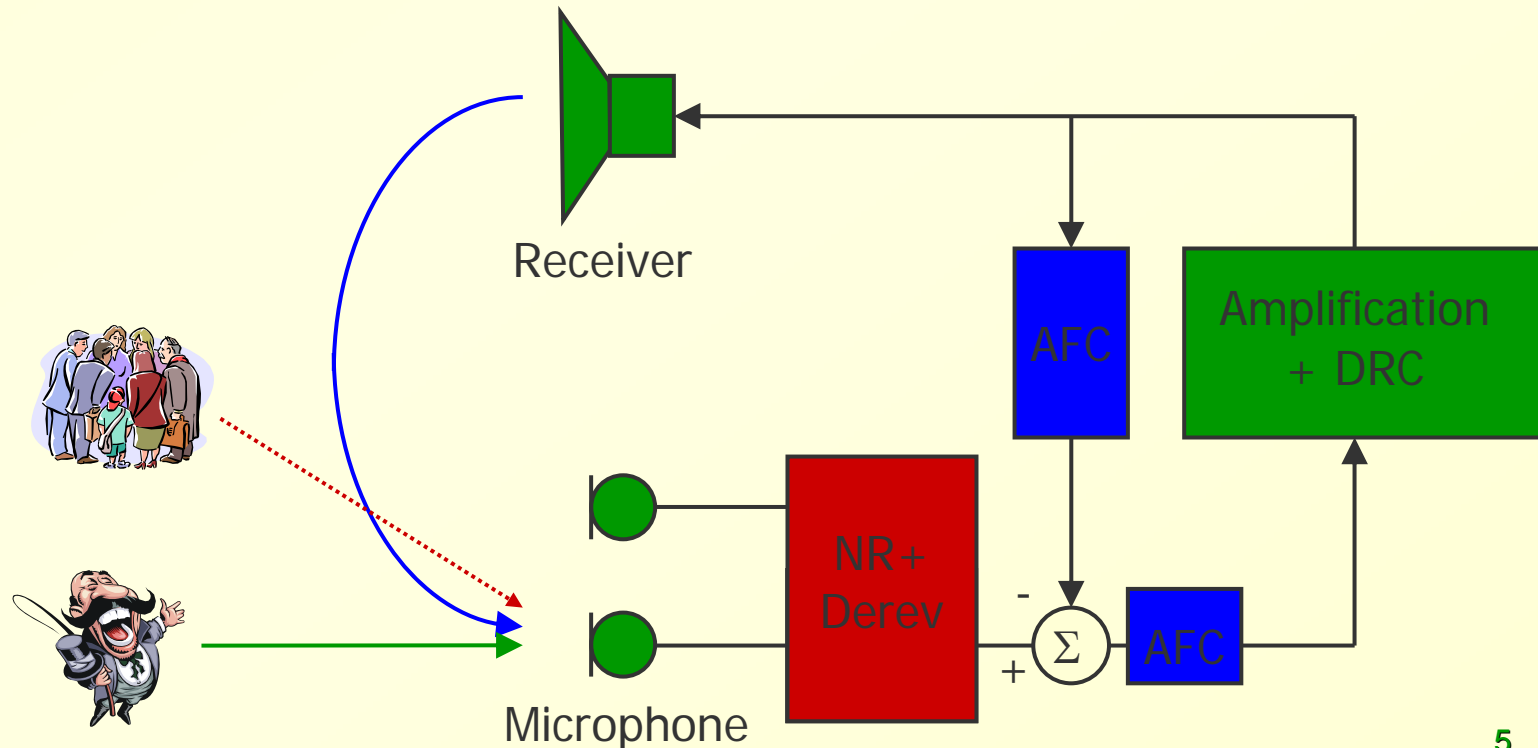

Hearing instruments

- Hearing aids
 - Problems
 - Bilateral - binaural
- Binaural processing
- Bandwidth reduction
- Acoustic sensor networks
- Conclusion

- Major problems: background noise, directional hearing
 - o signal processing to selectively enhance useful speech signal and improve **speech intelligibility**
 - o signal processing to preserve directional hearing (binaural auditory cues) and **spatial awareness**
 - o robustness important due to small inter-microphone distance
- Binaural auditory cues
 - o Interaural Time Difference (ITD) – Interaural Level Difference (ILD)
 - o Binaural cues, in addition to spectral and temporal cues, play an important role in binaural noise reduction and sound localisation
 - o ITD: $f < 1500\text{Hz}$, ILD: $f > 2000\text{Hz}$

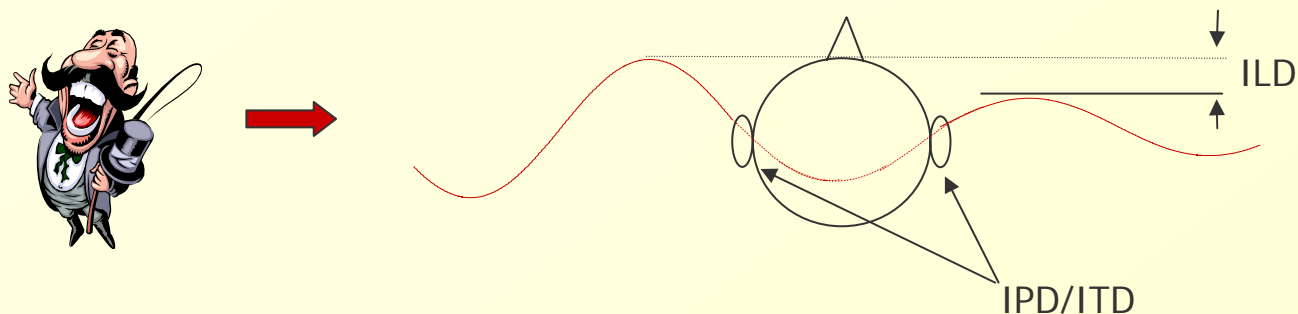

Bilateral vs. Binaural

- Hearing aids
 - Problems
 - Bilateral - binaural
- Binaural processing
- Bandwidth reduction
- Acoustic sensor networks
- Conclusion

Bilateral system

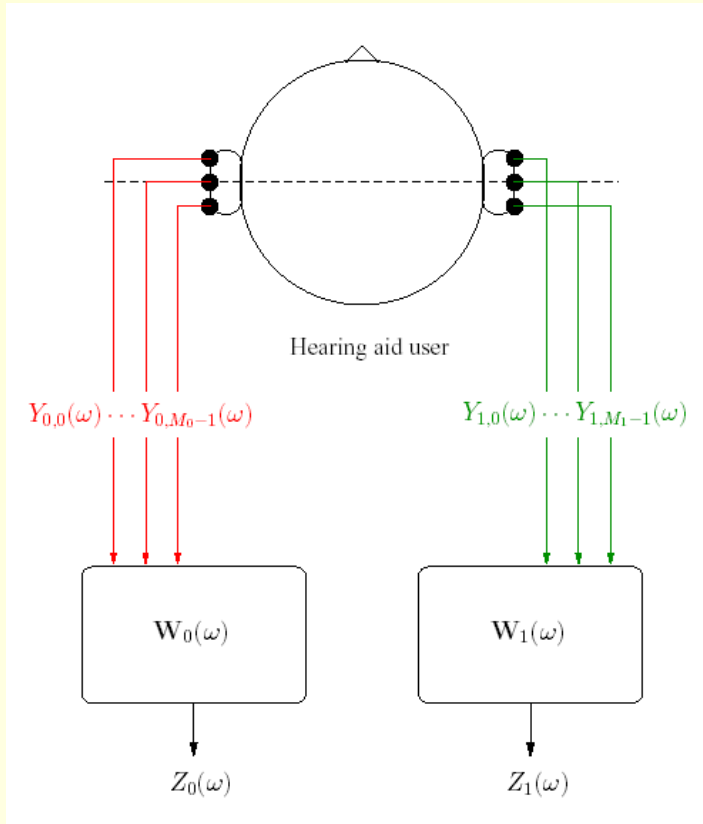

Binaural system

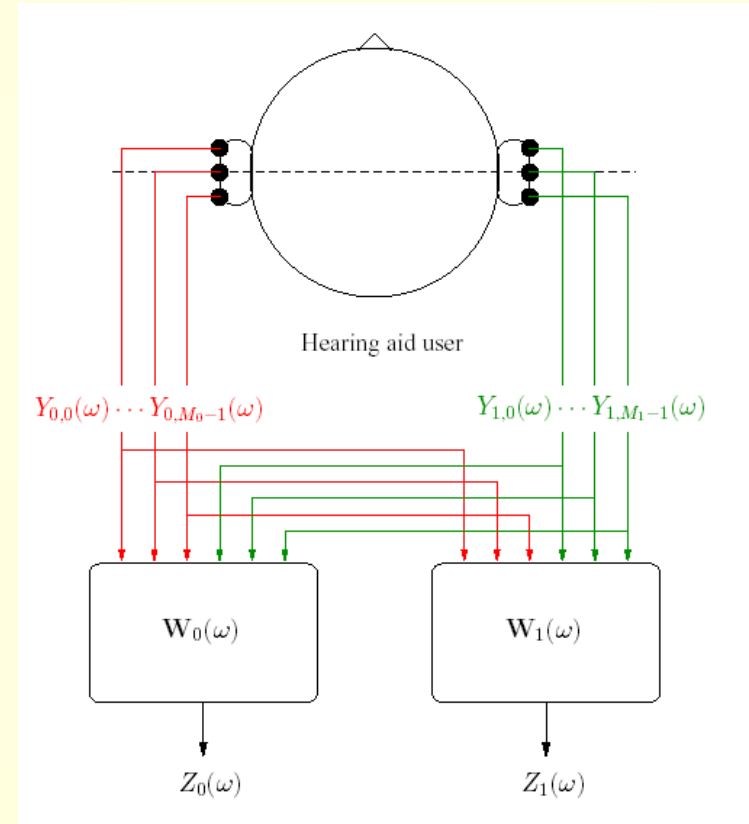

⊖ Independent left/right processing:
 Preservation of binaural cues
 for localisation ?

⊕ More microphones:
 → better performance ?
 → preservation of binaural cues ?

⊖ Need for wireless binaural link 7

Bilateral vs. Binaural

- Hearing aids
 - Problems
 - Bilateral - binaural
- Binaural processing
- Bandwidth reduction
- Acoustic sensor networks
- Conclusion

- Bilateral system:
 - o Independent processing of left and right hearing aid
 - o Negative effect on localisation cues and intelligibility through binaural hearing advantage [Van den Bogaert et al., 2006]

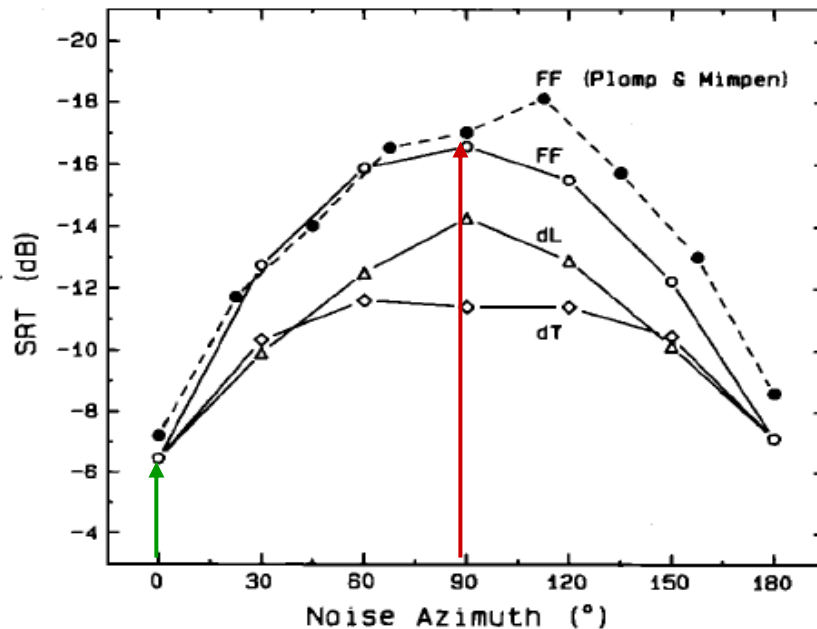
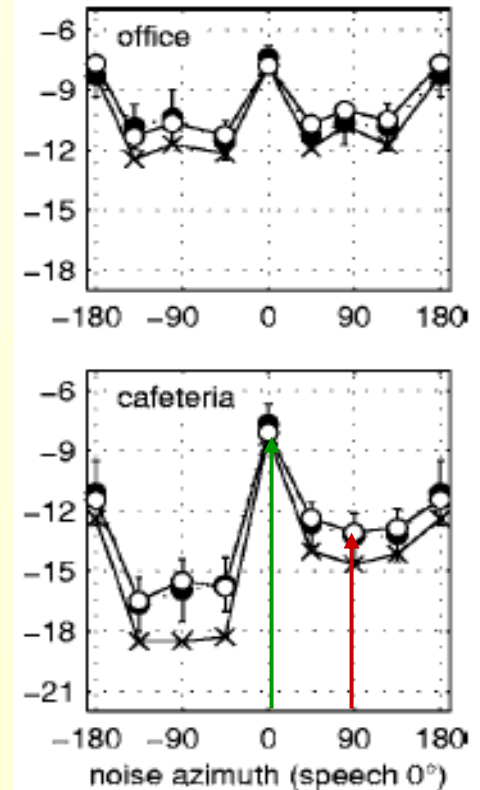

FIG. 5. Mean speech reception thresholds obtained in experiment I for three different noise types : FF (free field), dL (headshadow only), and dT (ITD only). The closed data points represent results of Plomp and Mimpen (1981) obtained in a free field.



Bilateral vs. Binaural

- Hearing aids
 - Problems
 - Bilateral - binaural
- Binaural processing
- Bandwidth reduction
- Acoustic sensor networks
- Conclusion

- Bilateral system
 - o Independent processing of left and right hearing aid
 - o Negative effect on localisation cues and intelligibility through binaural hearing advantage [Van den Bogaert et al., 2006]
- Binaural system
 - o Cooperation between left and right hearing aid (e.g. wireless link) → **centralised** vs. **distributed** processing
 - o Bandwidth constraint and latency of wireless link

Objectives/requirements for binaural algorithm:

1. SNR improvement: noise reduction, limit speech distortion
2. Preservation of binaural cues (all sources) to exploit binaural hearing advantage
3. No assumption about position of speech source and microphones

Binaural noise reduction techniques

- Hearing aids
- Binaural processing
 - Algorithms
 - Binaural MWF
 - Experiments
- Bandwidth reduction
- Acoustic sensor networks
- Conclusion

- **Configuration:** microphone array with M microphones at left and right hearing aid, communication between hearing aids

$$Y_{0,m}(\omega) = X_{0,m}(\omega) + V_{0,m}(\omega), \quad m = 0 \dots M_0 - 1$$

\uparrow \uparrow
 speech component noise component

- Vector notation: $\mathbf{Y}(\omega) = \mathbf{X}(\omega) + \mathbf{V}(\omega)$
- **One desired signal source:** $\mathbf{X}(\omega) = \mathbf{A}(\omega)S(\omega)$
 $\mathbf{A}(\omega)$ = transfer function (TF) vector between source and mic array

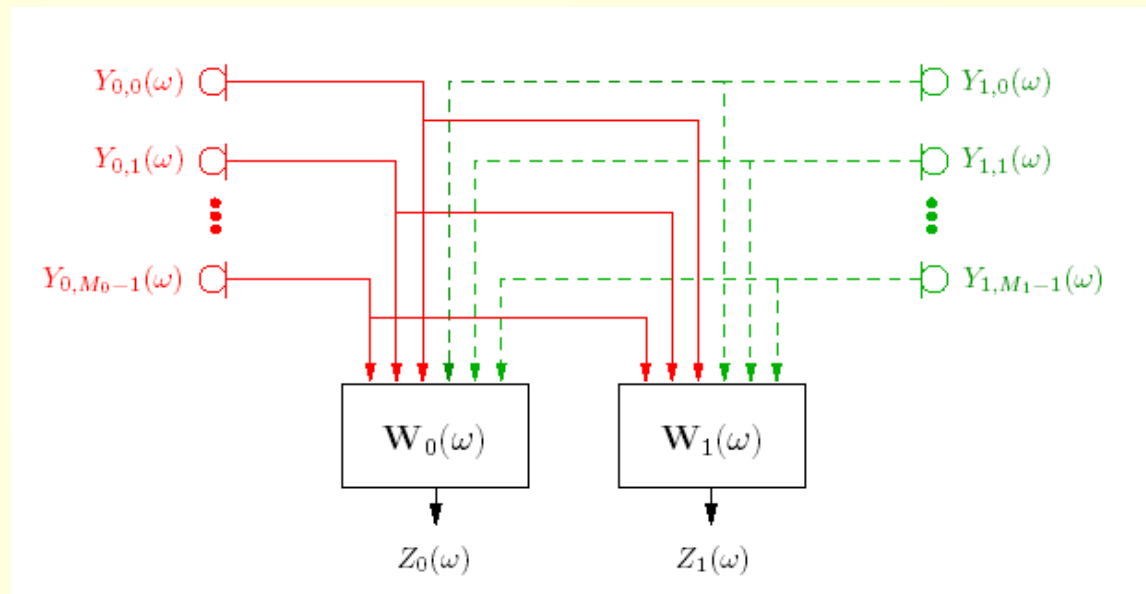

Binaural noise reduction techniques

- Hearing aids
- Binaural processing
 - Algorithms
 - Binaural MWF
 - Experiments
- Bandwidth reduction
- Acoustic sensor networks
- Conclusion

- Use microphone signals to compute **output signal at both ears**
→ computation of filters \mathbf{W}_0 and \mathbf{W}_1

$$Z_0(\omega) = \mathbf{W}_0^H(\omega)\mathbf{Y}(\omega), \quad Z_1(\omega) = \mathbf{W}_1^H(\omega)\mathbf{Y}(\omega)$$

$$\mathbf{W}(\omega) = \begin{bmatrix} \mathbf{W}_0(\omega) \\ \mathbf{W}_1(\omega) \end{bmatrix}$$

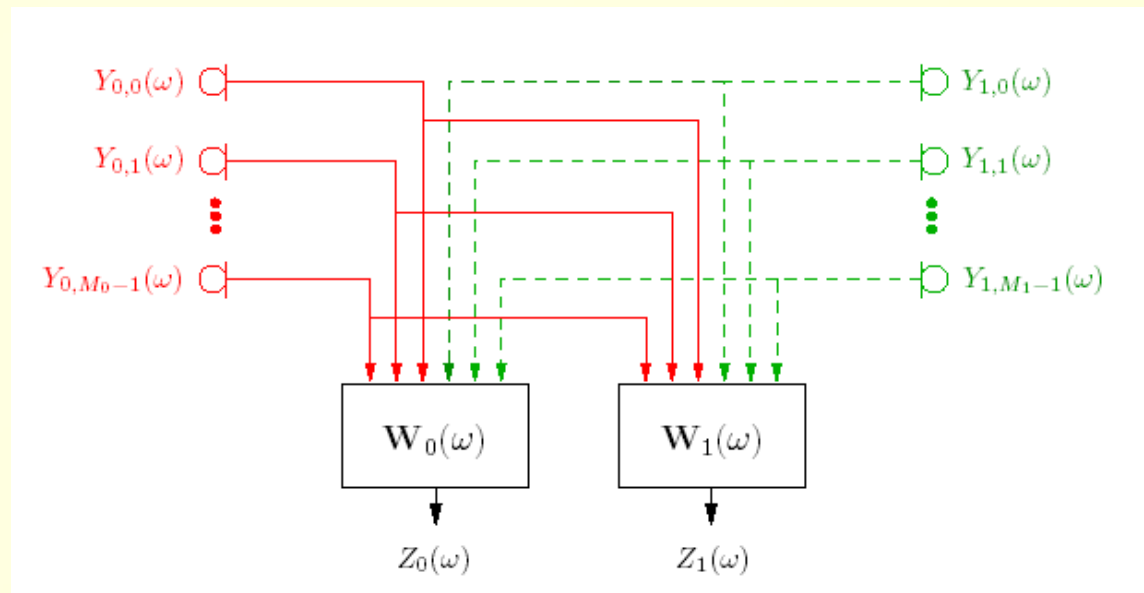

Binaural noise reduction techniques

- Fixed beamforming: spatial selectivity + binaural speech cues
 - Maximize directivity index while restricting speech ITD error [Desloge, 1997]
 - Superdirective beamformer using HRTFs [Lotter, 2004]
- ⊕ low computational complexity
- ⊖ limited performance, known geometry, only speech cues may be preserved (in ideal situations)

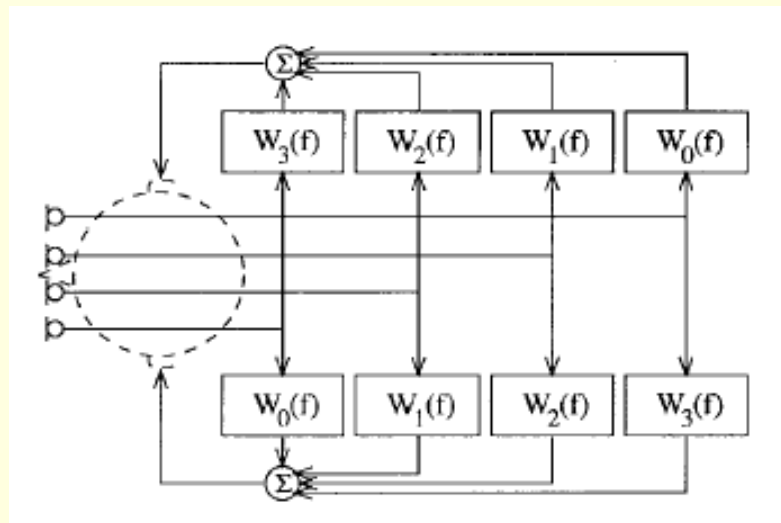

[Desloge, 1997]

Binaural noise reduction techniques

- Adaptive beamforming: based on GSC-structure
 - Divide frequency spectrum: low-pass portion unaltered to preserve ITD cues, high-pass portion processed using GSC

⊕ preserves binaural cues to some extent

⊖ substantial drop in noise reduction performance, known geometry

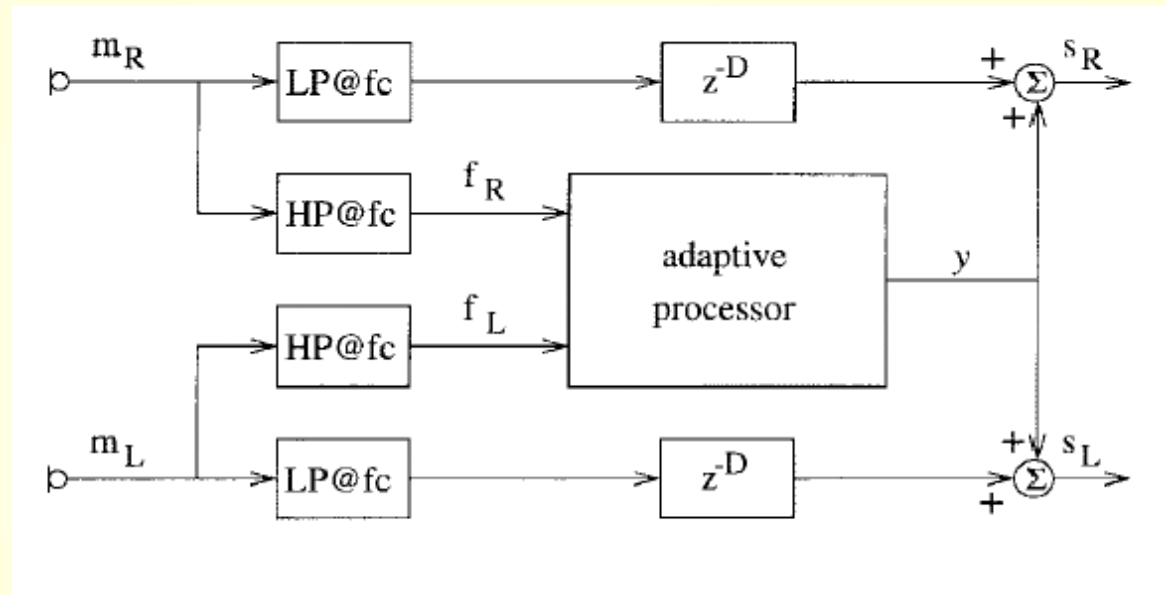

Binaural noise reduction techniques

- Hearing aids
- Binaural processing
 - Algorithms
 - Binaural MWF
 - Experiments
- Bandwidth reduction
- Acoustic sensor networks
- Conclusion

- Binaural multi-channel Wiener filter [Doclo, Van den Bogaert, Moonen]
 - MMSE estimate of speech component in microphone signal at both ears
 - ⊕ speech cues are preserved, **no a-priori assumptions** about position of speech source and microphones
 - ⊖ noise cues may be distorted



Extension of MWF :

preservation of binaural speech and noise cues
without substantially compromising noise
reduction performance

[S. Doclo, S. Gannot, M. Moonen, A. Spriet, Handbook on Array Processing and Sensor Networks, Wiley, 2010.]

[S. Doclo, T.J. Klasen, M. Moonen, T. Van den Bogaert, J. Wouters, R.P. Derleth, S. Korl, US2010002886.]

Binaural MWF

- Binaural multi-channel Wiener filter: estimate of speech component in microphone signal at both ears (usually front mic) + trade-off between noise reduction and speech distortion

$$J(\mathbf{W}) = E \left\{ \left\| \begin{bmatrix} X_{0,r_0} - \mathbf{W}_0^H \mathbf{X} \\ X_{1,r_1} - \mathbf{W}_1^H \mathbf{X} \end{bmatrix} \right\|^2 + \mu \left\| \begin{bmatrix} \mathbf{W}_0^H \mathbf{V} \\ \mathbf{W}_1^H \mathbf{V} \end{bmatrix} \right\|^2 \right\} \Rightarrow \mathbf{W}_{SDW} = \mathbf{R}^{-1} \mathbf{r}$$

speech component in front microphones
speech distortion
noise reduction

$$\mathbf{R} = \begin{bmatrix} \mathbf{R}_x + \mu \mathbf{R}_v & \mathbf{0}_M \\ \mathbf{0}_M & \mathbf{R}_x + \mu \mathbf{R}_v \end{bmatrix}, \quad \mathbf{r} = \begin{bmatrix} \mathbf{r}_{x0} \\ \mathbf{r}_{x1} \end{bmatrix}, \quad \mathbf{R}_x = \mathbf{R}_y - \mathbf{R}_v$$

estimate

- o Estimate \mathbf{R}_y during speech-dominated time-frequency segments, estimate \mathbf{R}_v during noise-dominated segments, requiring robust voice activity detection (VAD) mechanism
- o No assumptions about positions of microphones and sources
- o Low-cost real-time implementation using multi-channel frequency-domain criterion and stochastic gradient algorithm

- Hearing aids
- Binaural processing
 - Algorithms
 - Binaural MWF
 - Experiments
- Bandwidth reduction
- Acoustic sensor networks
- Conclusion

Binaural MWF

- Interpretation for a single speech source

- o Spectral and spatial filtering operation

$$\mathbf{W}_{SDW,0} = \frac{\Gamma_v^{-1} \mathbf{A}}{\mathbf{A}^H \Gamma_v^{-1} \mathbf{A}} \cdot \frac{\mathbf{A}^H \Gamma_v^{-1} \mathbf{A}}{\mathbf{A}^H \Gamma_v^{-1} \mathbf{A} + \mu P_v / P_s} \mathbf{A}_{0,r_0}^*$$

Spatial separation between
speech and noise sources

SNR

with Γ (spatial) coherence matrix and P (spectral) power

- o SNR improvement

$$\text{SNR}_L^{\text{out}} = \text{SNR}_R^{\text{out}} = \rho = P_s \mathbf{A}^H \mathbf{R}_v^{-1} \mathbf{A}$$

- o Binaural cues (ITD – ILD)

$$\mathbf{W}_{SDW,0} = \text{ITF}_{x,in}^* \mathbf{W}_{SDW,1}$$

- ⊕ Perfectly preserves binaural cues of speech component
- ⊖ Binaural cues of noise component → speech component !!

- Hearing aids
- Binaural processing
 - Algorithms
 - Binaural MWF
 - Experiments
- Bandwidth reduction
- Acoustic sensor networks
- Conclusion

Partial noise estimation (MWFv)

- Partial estimation of noise component

- o Estimate of sum of speech component and scaled noise component

$$J(\mathbf{W}) = E \left\{ \left\| \begin{bmatrix} X_{0,r_0} - \mathbf{W}_0^H \mathbf{X} \\ X_{1,r_1} - \mathbf{W}_1^H \mathbf{X} \end{bmatrix} \right\|^2 + \mu \left\| \begin{bmatrix} \eta V_{0,r_0} - \mathbf{W}_0^H \mathbf{V} \\ \eta V_{1,r_1} - \mathbf{W}_1^H \mathbf{V} \end{bmatrix} \right\|^2 \right\}, \quad 0 \leq \eta \leq 1$$

- o Relationship with SDW-MWF: mix with reference microphone signals

$$Z_0 = \eta Y_{0,r_0} + (1 - \eta) Z_{SDW,0}$$

$$Z_1 = \eta Y_{1,r_1} + (1 - \eta) Z_{SDW,1}$$

- ⊖ reduction of noise reduction, but not necessarily of intelligibility

$$\Delta SNR_L = \Delta SNR_L^o \frac{\left(\frac{\eta\mu + \rho}{\mu + \rho}\right)^2}{\left(\frac{\eta\mu + \rho}{\mu + \rho}\right)^2 + (\Delta SNR_L^o - 1)\eta^2}$$

- ⊕ binaural speech cues are preserved; binaural noise cues are weighted combination of input noise and speech cues

- ⊕ works for **multiple noise sources**

- Hearing aids
- Binaural processing
 - Algorithms
 - Binaural MWF
 - Experiments
- Bandwidth reduction
- Acoustic sensor networks
- Conclusion

Interaural Wiener filter (MWF-ITF)

- Hearing aids
- Binaural processing
 - Algorithms
 - Binaural MWF
 - Experiments
- Bandwidth reduction
- Acoustic sensor networks
- Conclusion

- Extension of SDW-MWF with binaural cues
 - Add term related to binaural cues of noise (and speech) component
 - Possible cues: ITD, ILD, **Interaural Transfer Function (ITF)**

$$\text{e.g. } ITF_{in}^v = \frac{V_{0,r_0}}{V_{1,r_1}} = \frac{E \{V_{0,r_0} V_{1,r_1}^*\}}{E \{V_{1,r_1} V_{1,r_1}^*\}} \quad ITF_{out}^v = \frac{Z_{v0}}{Z_{v1}} = \frac{\mathbf{W}_0^H \mathbf{V}}{\mathbf{W}_1^H \mathbf{V}}$$

$$J_{tot}(\mathbf{W}) = E \left\{ \left\| \begin{bmatrix} X_{0,r_0} - \mathbf{W}_0^H \mathbf{X} \\ X_{1,r_1} - \mathbf{W}_1^H \mathbf{X} \end{bmatrix} \right\|^2 + \mu \left\| \begin{bmatrix} \mathbf{W}_0^H \mathbf{V} \\ \mathbf{W}_1^H \mathbf{V} \end{bmatrix} \right\|^2 \right\} \\ + \alpha E \left\{ \left| \mathbf{W}_0^H \mathbf{X} - ITF_{in}^x \mathbf{W}_1^H \mathbf{X} \right|^2 \right\} + \beta E \left\{ \left| \mathbf{W}_0^H \mathbf{V} - ITF_{in}^v \mathbf{W}_1^H \mathbf{V} \right|^2 \right\}$$

\uparrow
ITF preservation speech
 \uparrow
ITF preservation noise

- ⊕ Closed form expression
- ⊕ Although output ITF of speech and noise component is equal, output ITF depends on output SNR → positive perceptual effect

$$ITF^{out} = \frac{ITF_x^{in} - \xi(ITF_x^{in} - ITF_v^{des})}{1 + \xi ITF_v^{des,*} (ITF_x^{in} - ITF_v^{des})}$$

- ⊖ Implicit assumption of **single noise source**, difficult parameter tuning

Experimental results

- Hearing aids
- Binaural processing
 - Algorithms
 - Binaural MWF
 - Experiments
- Bandwidth reduction
- Acoustic sensor networks
- Conclusion

- Identification of HRTFs
 - o Binaural recordings on CORTEX MK2 artificial head
 - o 2 omni-directional microphones on each hearing aid (d=1cm)
 - o LS = $-90^{\circ}:15^{\circ}:90^{\circ}$, $90^{\circ}:30^{\circ}:270^{\circ}$, 1m from head
 - o Conditions: $T_{60}=510$ ms, $f_s=16$ kHz

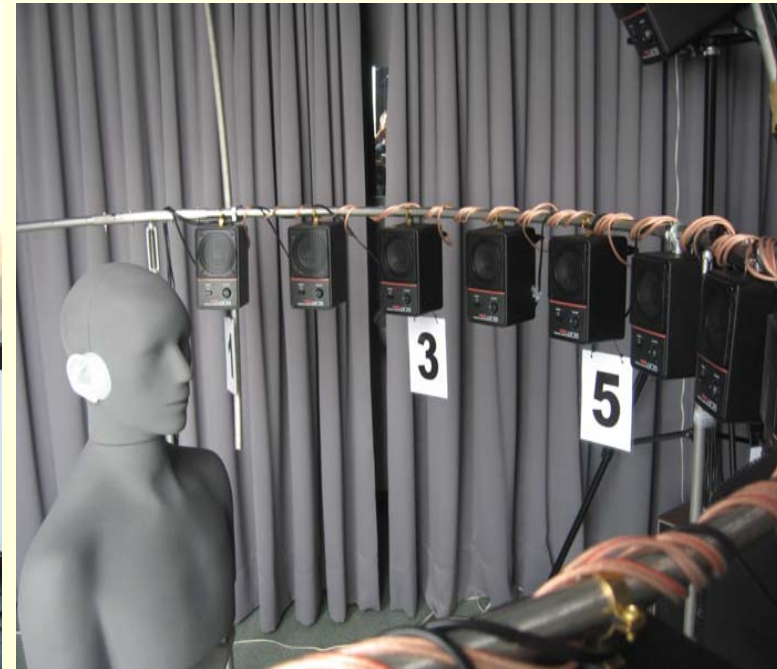
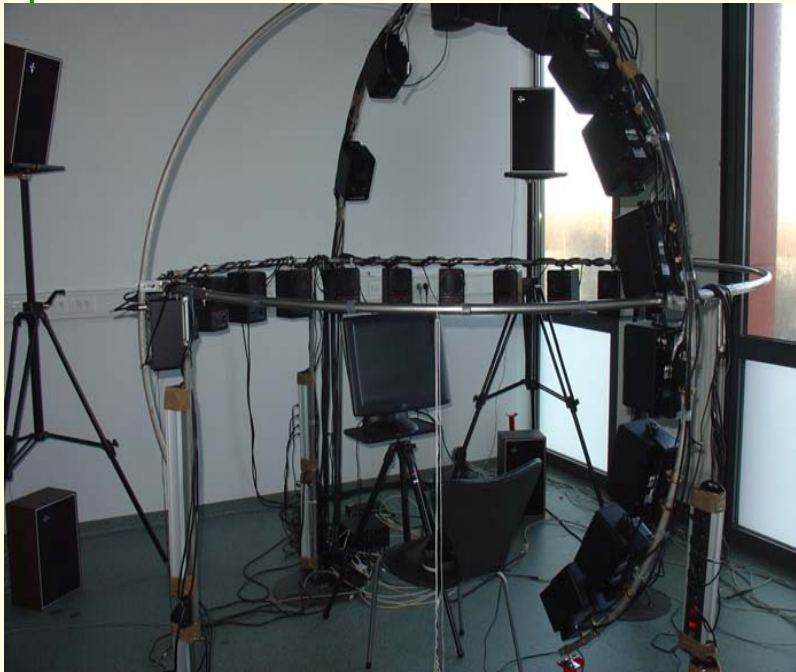

Perceptual evaluation: MWFv

- SRT measurements (headphone presentation, 10 normal-hearing)
- Speech sentences + babble noise
- Algorithms: state-of-the art bilateral (ADM), MWF, MWFv ($\eta=0.2$)
- Conditions: S_0N_{60} , $S_{90}N_{270}$ and $S_0N_{90/180/270}$

- Hearing aids
- Binaural processing
 - Algorithms
 - Binaural MWF
 - Experiments
- Bandwidth reduction
- Acoustic sensor networks
- Conclusion

Bilat/bin Δ SRT (dB)	S_0N_{60}			$S_{90}N_{270}$			$S_0N_{90/180/270}$		
	Perceptual	Left	Right	Perceptual	Left	Right	Perceptual	Left	Right
ADM	2.1 ± 1.9	2.7	2.8	-4.3 ± 1.3*	4.3	-3.2	1.3 ± 1.4	6.0	5.9
MWF ₂₊₂	4.3 ± 1.5*	4.9	9.6	0.7 ± 1.4	10.0	2.5	4.6 ± 0.8*	7.1	7.2
MWF ₂₊₁	3.8 ± 1.6*	4.0	6.2	0.3 ± 2.0	9.6	2.1	4.0 ± 1.5*	6.6	6.0
MWF ₂₊₀	1.0 ± 0.7*	1.9	3.3	-1.2 ± 1.6	3.8	1.0	2.8 ± 1.3*	5.1	4.9
MWF ₂₊₂ -N _{0.2}	3.6 ± 1.4*	3.3	5.4	2.0 ± 1.4*	4.3	1.9	3.2 ± 0.8*	4.1	4.2
MWF ₂₊₁ -N _{0.2}	2.7 ± 1.3*	2.6	3.0	1.5 ± 1.6	3.9	1.6	3.4 ± 0.8*	3.7	3.3
MWF ₂₊₀ -N _{0.2}	1.0 ± 2.1	1.1	0.9	0.0 ± 1.5	1.0	0.7	2.3 ± 1.4*	2.8	2.6

Perceptual evaluation: MWFv

- Algorithms: unprocessed, state-of-the art bilateral, MWF, MWFv ($\eta=0.2$)
- Conditions: S_0N_{60} , $S_{45}N_{315}$ and $S_{90}N_{270}$

- Hearing aids
- Binaural processing
 - Algorithms
 - Binaural MWF
 - Experiments
- Bandwidth reduction
- Acoustic sensor networks
- Conclusion

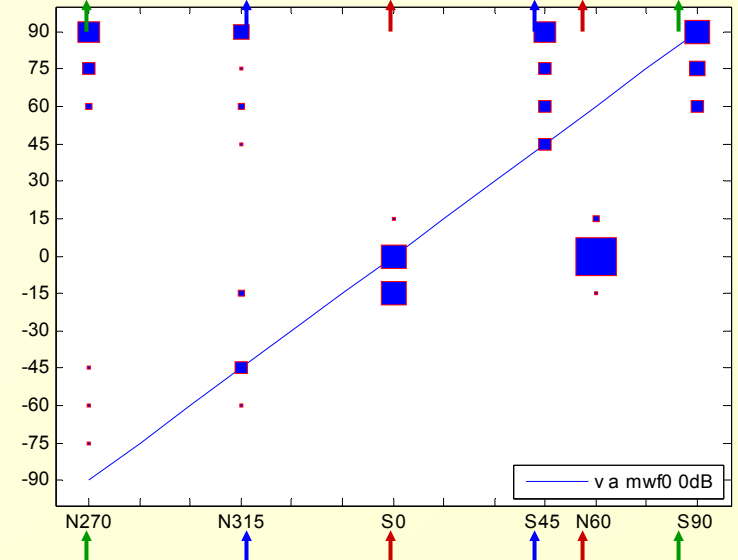
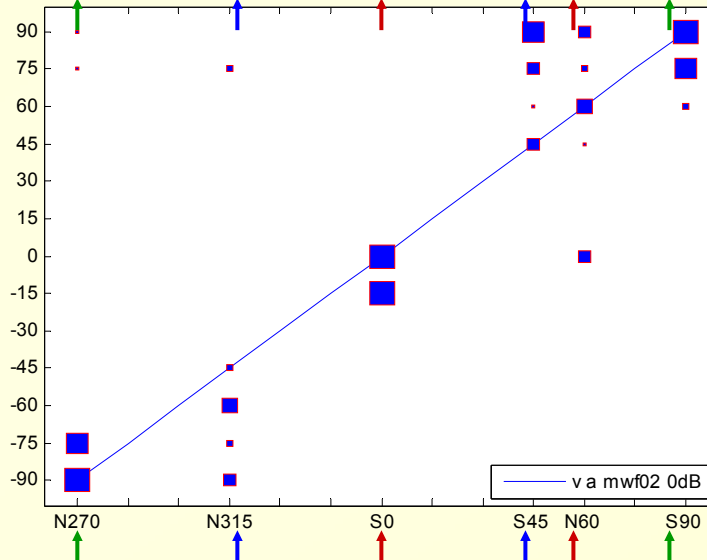
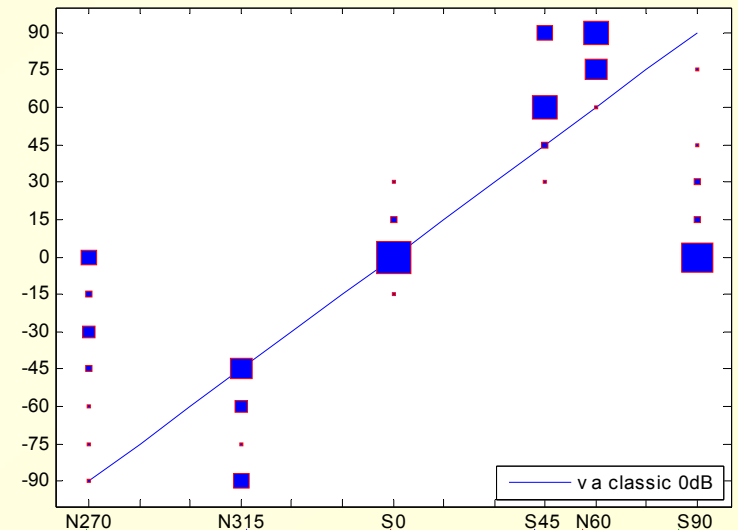
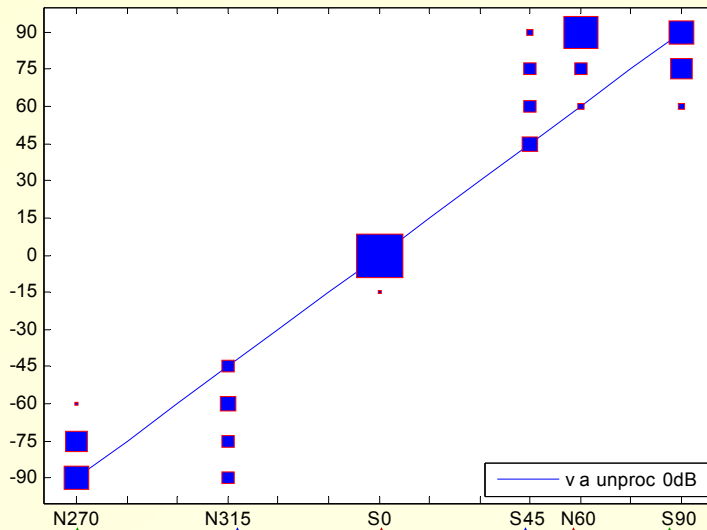









[T. Van den Bogaert, S. Doclo, J. Wouters, M. Moonen, Journal of the Acoustical Society of America, Jan. 2009.]

Audio demo

- Hearing aids
- Binaural processing
 - Algorithms
 - Binaural MWF
 - Experiments
- Bandwidth reduction
- Acoustic sensor networks
- Conclusion

- Speech and noise material:
 - o HINT sentences, speech source in front (0°)
 - o Multi-talker babble noise at 60°
 - o SNR=0 dB, $f_s=16$ kHz, FFT-size $N=256$, $\mu=1$, $\alpha=0$

	Noisy	Speech	Noise
Input			
Output ($\beta=0$)			
Output ($\beta=0.05$)			

Binaural processing

- Hearing aids
- Binaural processing
 - Algorithms
 - Binaural MWF
 - Experiments
- Bandwidth reduction
- Acoustic sensor networks
- Conclusion

- Remaining challenges
 - o Algorithm exploiting information in **all** microphones, preserving binaural cues for **all** sources
 - o Psycho-acoustics: how much **distortion of binaural cues** can be tolerated
 - related to good **objective measures**

Distributed MWF

- Binaural MWF
 - **all** microphone signals are transmitted over wireless link
- Reduce **bandwidth requirement** of wireless link by transmitting **one** signal from contralateral ear
 - Raw microphone signal (e.g. front)
 - Output of fixed (e.g. superdirective) beamformer
 - MWF-estimate using only contralateral microphone signals
 - **Iterative distributed binaural MWF scheme (DB-MWF)**

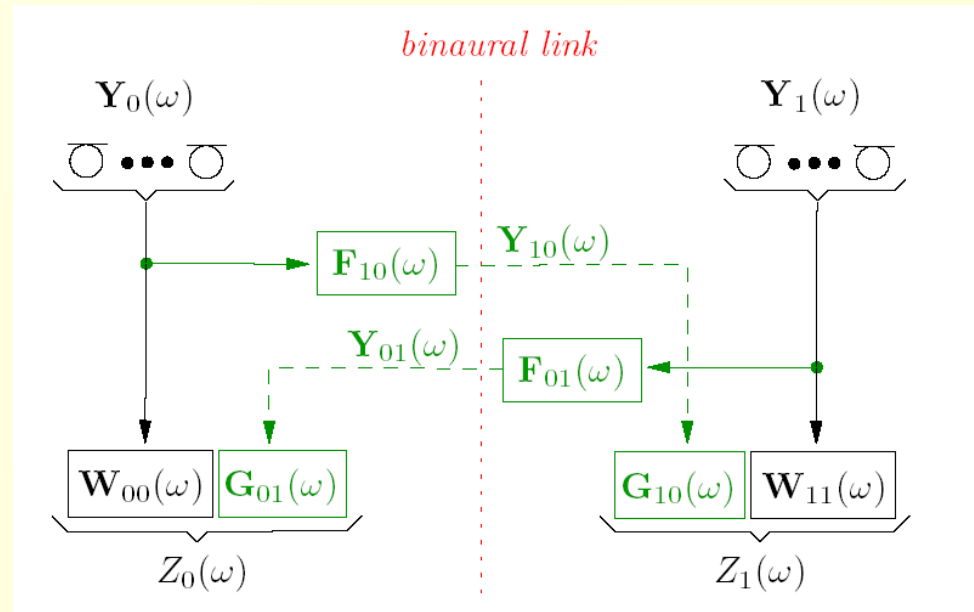

Distributed MWF

- Iterative procedure

- In each iteration \mathbf{F}_{10} is equal to \mathbf{W}_{00} from previous iteration, and \mathbf{F}_{01} is equal to \mathbf{W}_{11} from previous iteration

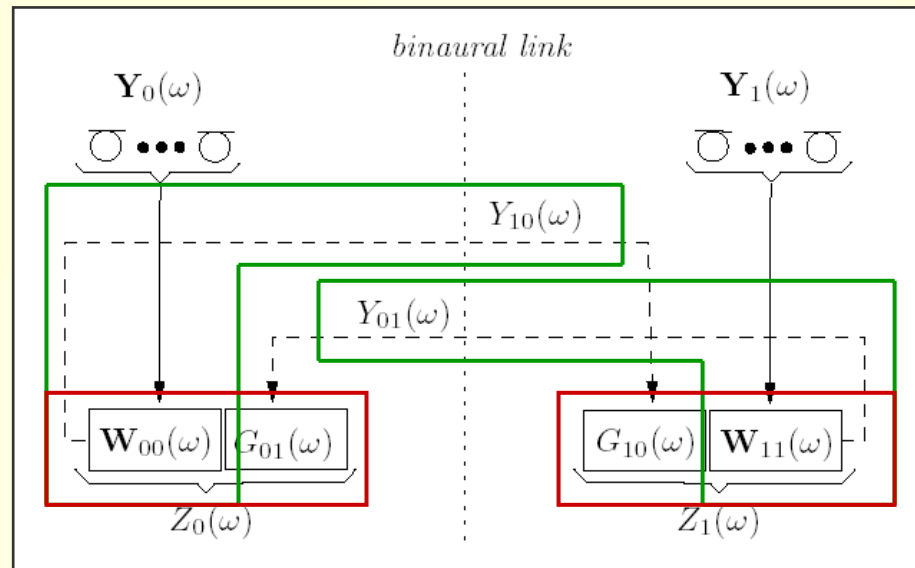

$$\mathbf{W}_0^i = \begin{bmatrix} \mathbf{W}_{00}^i \\ G_{01}^i \mathbf{W}_{11}^i \end{bmatrix}$$

$$\mathbf{W}_1^i = \begin{bmatrix} \mathbf{W}_{10}^i \\ \mathbf{W}_{11}^i \end{bmatrix}$$

$$\mathbf{W}_1^{i+1} = \begin{bmatrix} G_{10}^{i+1} \mathbf{W}_{00}^i \\ \mathbf{W}_{11}^{i+1} \end{bmatrix}$$

$$\mathbf{W}_0^{i+1} = \begin{bmatrix} \mathbf{W}_{00}^{i+1} \\ G_{01}^{i+1} \mathbf{W}_{11}^{i+1} \end{bmatrix}$$

Distributed MWF

- Single speech source

- o MWF cost function decreases in each step of iteration

$$J\left(\begin{bmatrix} \mathbf{W}_0^{i+1} \\ \mathbf{W}_1^{i+1} \end{bmatrix}\right) \leq J\left(\begin{bmatrix} \mathbf{W}_0^i \\ \mathbf{W}_1^i \end{bmatrix}\right)$$

- o Remarkably: convergence to B-MWF solution (!)



$$\mathbf{W}_0^\infty = \mathbf{W}_0^m, \quad \mathbf{W}_1^\infty = \mathbf{W}_1^m$$

- General case where \mathbf{R}_x is not a rank-1 matrix

- o MWF cost function does not necessarily decrease in each iteration
- o usually **no convergence to optimal B-MWF solution**
- o Although $J_0(\mathbf{W}_0^\infty) \geq J_0(\mathbf{W}_0^m)$, $J_1(\mathbf{W}_1^\infty) \geq J_1(\mathbf{W}_1^m)$, DB-MWF procedure can be used in practice and approaches binaural MWF performance

- Procedure can be **extended** to

- o Multiple sensor arrays and multiple desired sources [Bertrand 2010]
- o Binaural MVDR-beamformer [Golan 2010]

- Hearing aids
- Binaural processing
- Bandwidth reduction
 - Distributed MWF
 - Rate constraints
- Acoustic sensor networks
- Conclusion

Distributed MWF

Performance comparison (left, $L=128$, $T_{60}=500$ ms)

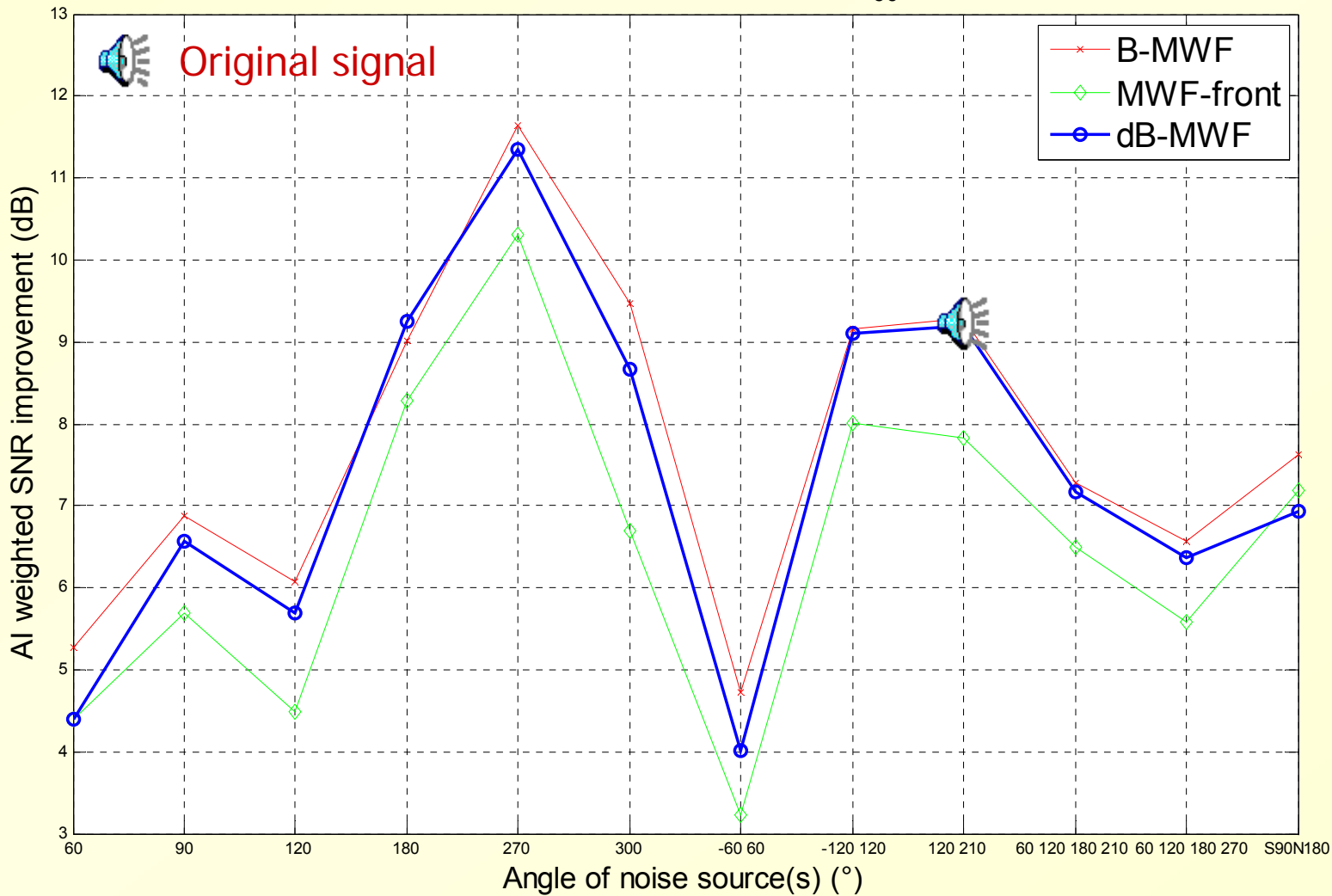

Real-world performance of DB-MWF close to full binaural MWF !

- Hearing aids
- Binaural processing
- Bandwidth reduction
 - Distributed MWF
 - Rate constraints
- Acoustic sensor networks
- Conclusion

Contralateral directivity patterns

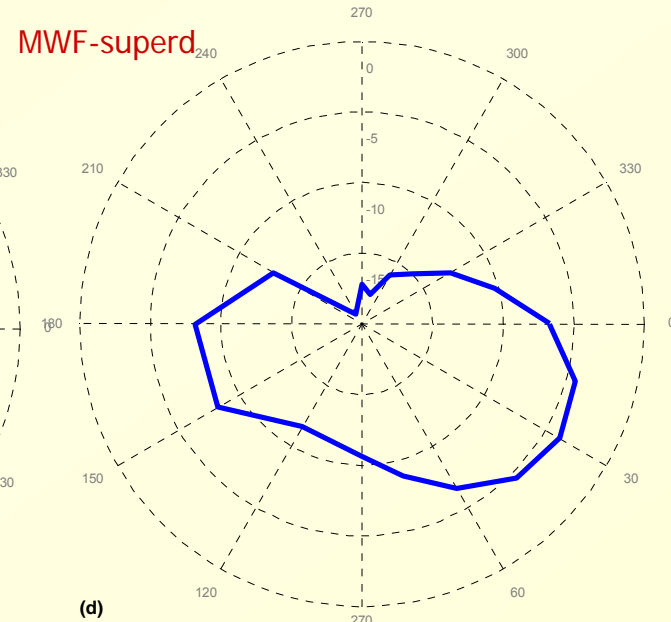
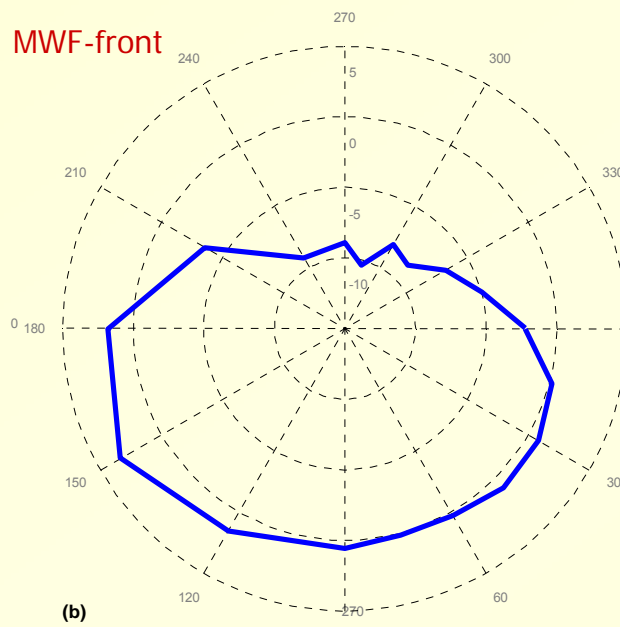
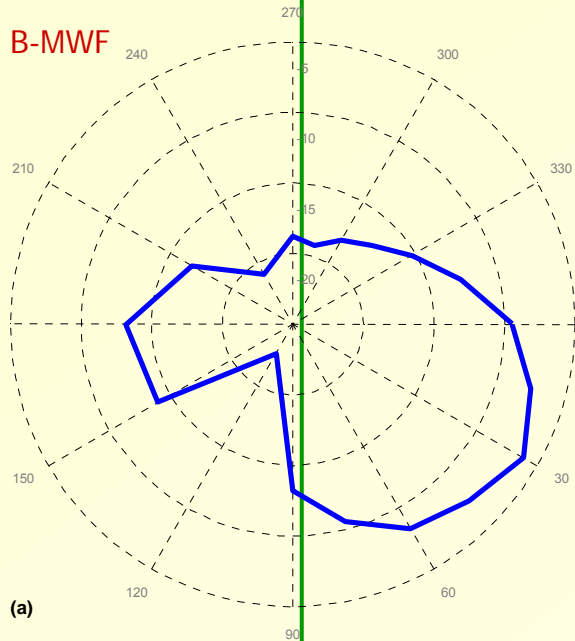

$$\theta_V = [-120^\circ \ 120^\circ]$$

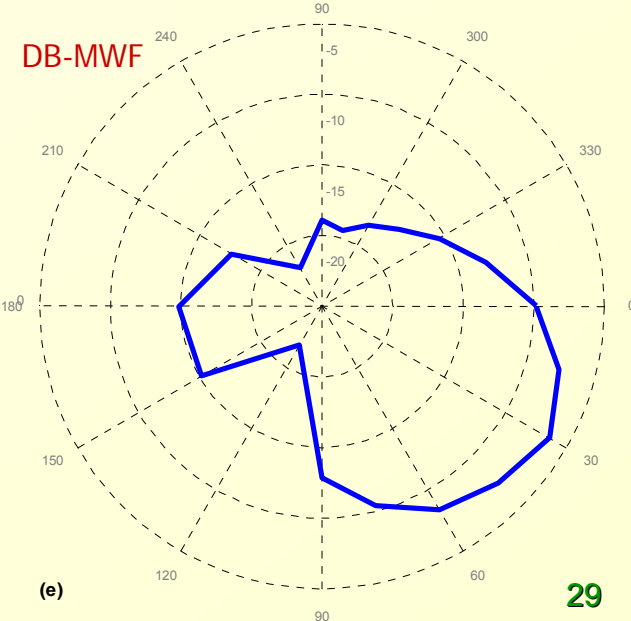
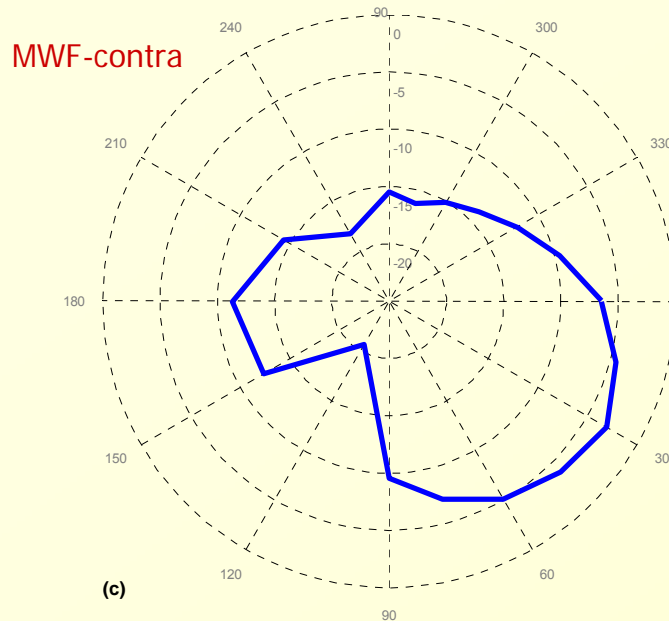

Rate constraints

- Hearing aids
- Binaural processing
- Bandwidth reduction
 - Distributed MWF
 - Rate constraints
- Acoustic sensor networks
- Conclusion

- Investigate effect of **capacity of binaural link** → encode signal(s) at finite bit-rate R before transmission to contralateral side

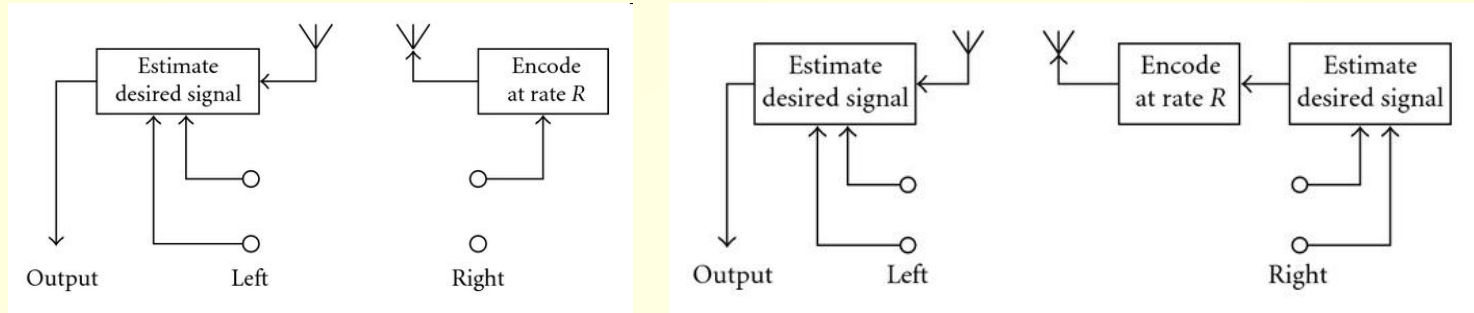

- Rate-distortion:

$$R(\lambda) = \frac{1}{4\pi} \int_{-\infty}^{\infty} \max\left(0, \log_2 \frac{\Phi_Y^{01}(\omega)}{\lambda}\right) d\omega$$

$$D(\lambda) = \frac{1}{2\pi} \int_{-\infty}^{\infty} \min(\lambda, \Phi_Y^{01}(\omega)) d\omega,$$

PSD of transmitted signal $Y_{01}(\omega)$

- Upper bound on achievable performance can be calculated using **forward channel representation**

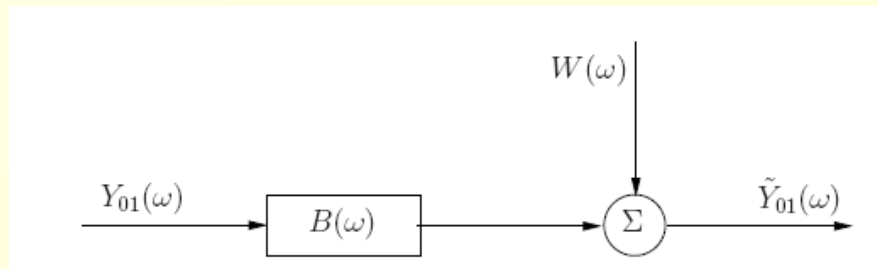

$$B = \max\left(0, \frac{\Phi_Y^{01} - \lambda}{\Phi_Y^{01}}\right)$$

$$\Phi_W = \max\left(0, \lambda \frac{\Phi_Y^{01} - \lambda}{\Phi_Y^{01}}\right)$$

Rate constraints

- Hearing aids
- Binaural processing
- Bandwidth reduction
 - Distributed MWF
 - Rate constraints
- Acoustic sensor networks
- Conclusion

- Investigate effect of rate constraints on **performance of binaural MWF and distributed MWF**
- Setup and performance measures:
 - o Binaural hearing aid configuration ($M=2$, $d=1\text{cm}$)
 - o Speech source at 0° , interference at 330° , uncorrelated noise

$$\Phi_y = \Phi_s \mathbf{A}_s \mathbf{A}_s^H + \Phi_i \mathbf{A}_i \mathbf{A}_i^H + \Phi_u \mathbf{I}_{2M}$$

- Involved PSDs are assumed to be flat (8 kHz), SIR=0 dB, SNR=20 dB
- ATFs modelled using spherical head shadow model, no reverberation
- o MWF-based algorithms: $\mu=1$
- o **Performance measure**: ratio between MSE at rate 0 and MSE at rate R , *i.e.* effect of availability of binaural link

$$G(R) = 10 \log_{10} \frac{\xi(0)}{\xi(R)}$$

ps. only performance at left hearing aid is shown

Rate constraints

- Hearing aids
- Binaural processing
- Bandwidth reduction
 - Distributed MWF
 - Rate constraints
- Acoustic sensor networks
- Conclusion

- Effect on performance of **binaural MWF**

- Total link capacity R distributed between front/back microphone

$$R_f = (1 - \rho)R, \quad R_b = \rho R$$

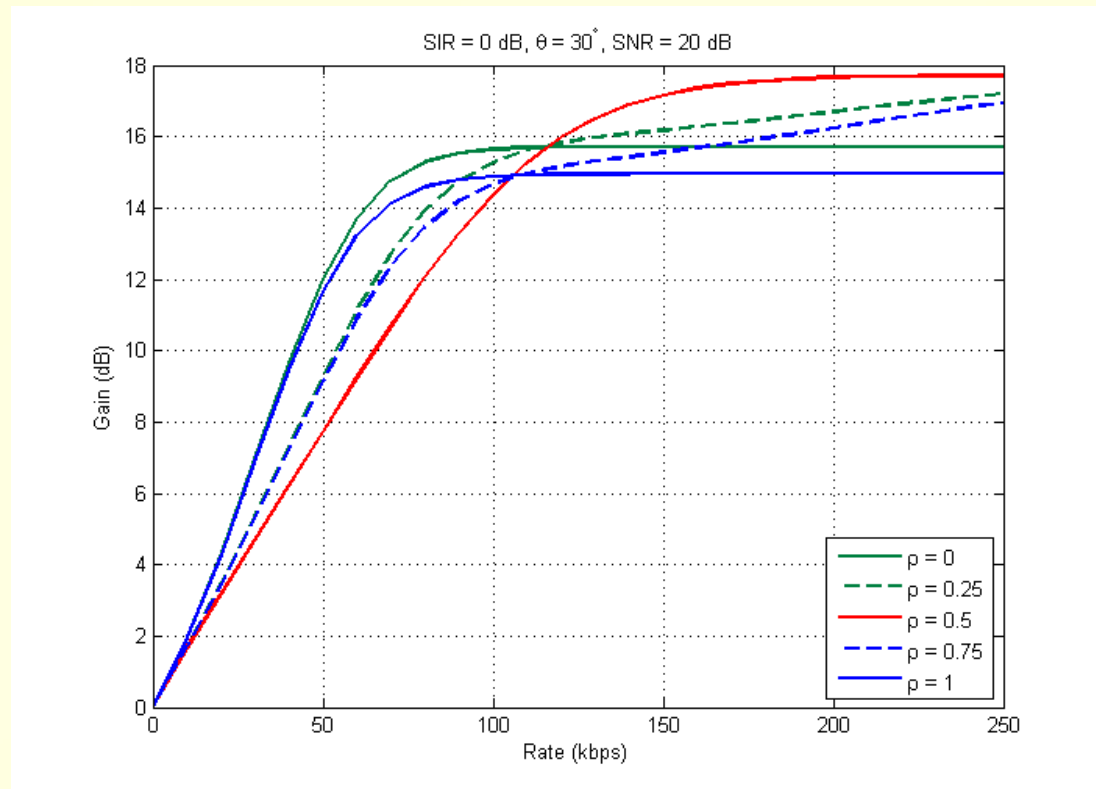

- For low bit-rate highest performance when transmitting single mic, **from certain bit-rate beneficial transmitting both mics**

Rate constraints

- Hearing aids
- Binaural processing
- Bandwidth reduction
 - Distributed MWF
 - Rate constraints
- Acoustic sensor networks
- Conclusion

- Effect on performance of distributed MWF
 - Single signal is compressed/transmitted in each iteration
 - **Case 1:** total capacity R evenly distributed between iterations

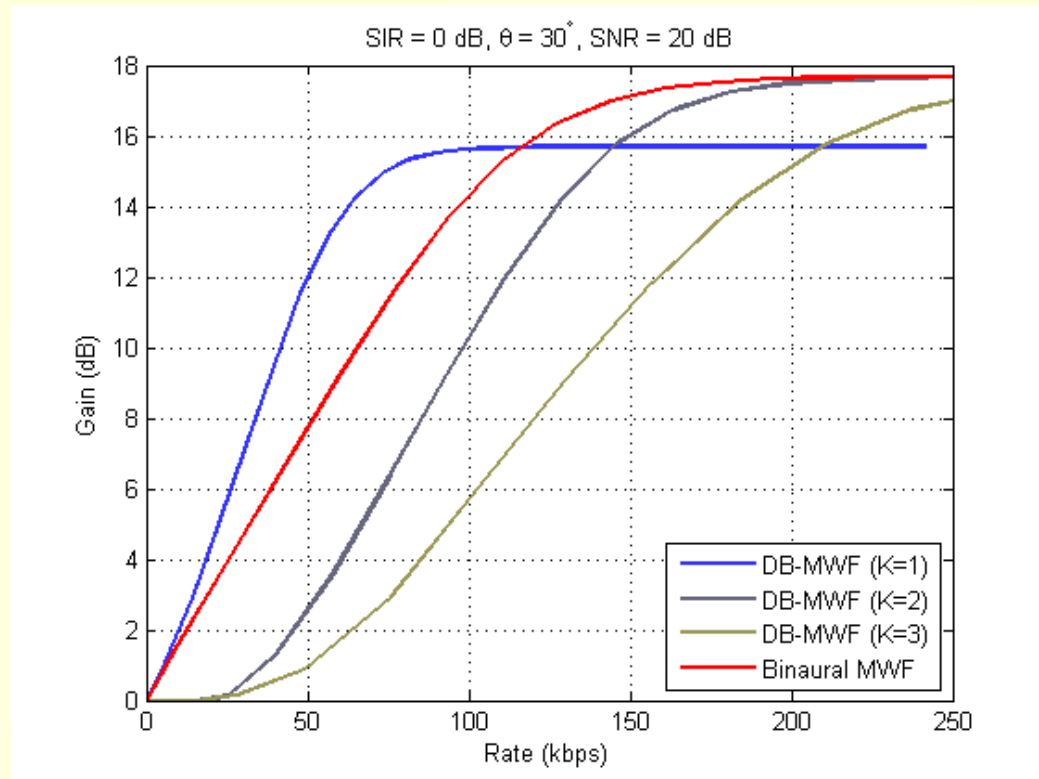

- For **infinite rate**, DB-MWF converges to B-MWF
- **More iterations** only improve performance at high rates

Rate constraints

- Hearing aids
- Binaural processing
- Bandwidth reduction
 - Distributed MWF
 - Rate constraints
- Acoustic sensor networks
- Conclusion

- Effect on performance of distributed MWF
 - Single signal is compressed/transmitted in each iteration
 - **Case 2:** spread iterations over subsequent frames (stationarity)

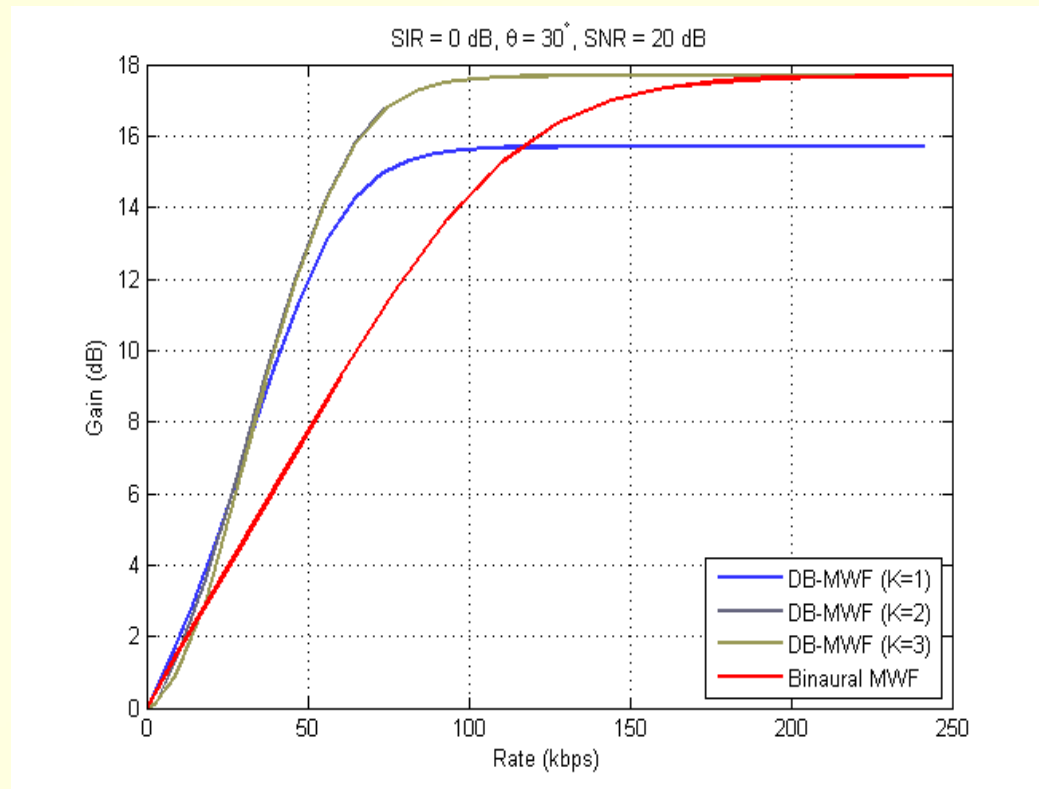

- **DB-MWF scheme** converges after $K=2$ iterations, moreover achieving **highest performance gain**

Binaural processing

- Hearing aids
- Binaural processing
 - Algorithms
 - Binaural MWF
 - Experiments
- Bandwidth reduction
- Acoustic sensor networks
- Conclusion

- Remaining challenges
 - o Algorithm exploiting information in **all** microphones, preserving binaural cues for **all** sources
 - o Psycho-acoustics: how much **distortion of binaural cues** can be tolerated
 - related to good **objective measures**
 - o **(Perceptual) coding** of transmitted signal
 - o **Technical issues of wireless link:**
 - Latency requirements
 - Synchronisation between both hearing aids

Extension to more mic arrays...

- Hearing aids
- Binaural processing
- Bandwidth reduction
- Acoustic sensor networks
- Conclusion

- Ad-hoc acoustic sensor networks
 - o Network of tens of small, low-power microphones with wireless communication capability → improvement in performance and flexibility (ambient intelligence)
 - o **Objectives:** speech enhancement and source localisation
 - o **Prototype applications:**
 - Hearing aids using extra microphones (room, mobile phones, ...)
 - Video-conferencing using all microphones on laptops / room
 - o **Challenges:**
 - *Dynamic array configuration:* large number of microphones at unknown positions, dynamically select subset of microphones
 - *Distributed and collaborative algorithms*
 - *Synchronisation issues*
 - o Useful in other, e.g. biomedical and digital communication, applications (body area network)



Conclusions

- Hearing aids
- Binaural processing
- Bandwidth reduction
- Acoustic sensor networks
- Conclusion

- Signal processing in **binaural hearing instruments**
 - Objective: noise reduction and preservation of binaural cues
 - Information exchange and collaboration through wireless link
 - Algorithms: beamforming, CASA, MWF
- **Bandwidth reduction** by transmitting filtered combination of contralateral microphone signals
 - Raw microphone signal, contralateral MWF estimate
 - DB-MWF: iterative procedure, which **converges to B-MWF** for rank-1 speech correlation matrix
- Effect of **bit-rate** on performance using rate-distortion theory
 - DB-MWF achieves highest performance gain, when iterations can be spread over subsequent frames
- Extension: distributed processing in **acoustic sensor networks**
 - Challenges: dynamic array configuration, collaborative algorithms
 - Mounting interest: **half of papers in best student session!**

Questions ?



House of Hearing, Oldenburg